

**Specification for Multi-touch Projected Capacitive Touch Panel**

1. GENERAL SPECIFICATIONS..... 2

2. MECHANICAL SPECIFICATIONS..... 2

3. ABSOLUTE MAXIMUM RATINGS .....2, 3

4. ELECTRICAL CHARACTERISTICS.....3

5. TIMING CHARACTERISTICS..... 3, 4, 5

6. OPTICAL CHARACTERISTICS..... 5

7. MECHANICAL CHARATERISTICS..... 5

8. OUTLINE DIMENSIONS..... 6

9. BLOCK DIAGRAM..... 6

10. INTERFACE SIGNALS..... 7

11. PROCOTOL..... 7, 8

12. INSPECTION CONDITIONS..... 8

13. INSPECTION STANDARDS..... 9

14. GENERAL RELIABLITY ASSURANCE .....10

15. ATTENTION .....10

## 1. GENERAL SPECIFICATIONS

1. 1 GENERAL SPECIFICATIONS THIS SPECIFICATION IS APPLIED TO PROJECTED CAPACITIVE TOUCH SCREEN MODULES, WHICH THE MODEL OF CUSTOMER IS SPECIFIED, TO STIPULATE THE QUALITY PERFORMANCE CONTROL.

1. 2 APPLICATION NOTES FOR CONTROLLER/DRIVER PLEASE REFER TO:  
CYRESS CY8CTST120

1 . 3 MATERIAL SAFETY DESCRIPTION ASSEMBLIES SHALL COMPLY WITH EDT GREEN PRODUCT (GP) REQUIREMENTS, INCLUDING PROHIBITED MATERIALS/COMPONENTS CONTAINING LEAD, MERCURY, CADMIUM, HEXAVALENT CHROMIUM, POLYBROMINATED BIPHENYLS (PBB), POLYBROMINATED DIPHENYL ETHERS (PBDE), POLYCHLORINATED BIPHENYLS (PCB) CATEGORY, POLYCHLORINATED NAPHTHALENE (PCN) CATEGORY, POLYCHLORINATED TERPHENYLS (PCT) CATEGORY, CHLORINATED PARAFFINS (CP) CATEGORY, TRIBUTHYL TIN CATEGORY / TRIPHENYL TIN CATEGORY, ASBESTOS, SPECIFIC AZO COMPOUNDS, FORMALDEHYDE, POLYVINYL CHLORIDE (PVC) AND PVC BLENDS, OTHER BROMINATED ORGANIC COMPOUNDS AND OTHER CHLORINATED ORGANIC COMPOUNDS.

## 2. MECHANICAL SPECIFICATIONS

- (1) TOUCH PANEL SIZE -----7.0 inch
- (2) OUTER DIMENSION -----164W \* 104H \* 1.5D(MAX. ) mm (WITHOUT FPC)
- (3) ACTIVE AREA -----154W \* 93.045H mm
- (4) INPUT TYPE -----MULTI-TOUCH
- (5) TOUCH SENSOR TRACES NUMBER -----25\*15 SENSORS
- (6) TOUCH MODULE RESOLUTION -----2048\*2048
- (7) INTERFACE MODE -----I2C

## 3. ABSOLUTE MAXIMUM RATINGS

### 3.1 ELECTRICAL ABSOLUTE MAXIMUM RATINGS.

PARAMETER	SYMBOL	MIN.	MAX.	UNIT	REMARK
POWER SUPPLY FOR DRIVER IC	-0.5	—	6	V	
DC INPUT VOLTAGE	VSS-0.5	—	VDD+0.5	V	
STATIC ELECTRICITY	—	—	100	V	NOTE ( 1 )

NOTE ( 1 ) : TEST METHOD AND CONDITIONS: AFTER CHARGING UP 200 pF CAPACITOR BY STATED VOLTAGE, THE CAPACITOR IS CONNECTED WITH INTERFACE PINS OF THE MODULE.

### 3.2 ENVIRONMENTAL ABSOLUTE MAXIMUM RATINGS

I T E M	OPERATING		STORAGE		REMARK
	MIN.	MAX.	MIN.	MAX.	
AMBIENT TEMPERATURE	- 2 0 ° C	7 0 ° C	- 3 0 ° C	8 0 ° C	NOTE ( 1 )
HUMIDITY	NOTE ( 2 )		NOTE ( 2 )		WITHOUT CONDENSATION
VIBRATION	—	2.45 m /s <sup>2</sup> ( 0.25 G )	—	11.76 m /s <sup>2</sup> ( 1.2 G )	10~100 Hz XYZ DIRECTIONS 1 Hr . EACH
SHOCK	—	29.4 m /s <sup>2</sup> ( 3 G )	—	490.0 m /s <sup>2</sup> ( 5 0 G )	10 mSECONDS XYZ DIRECTIONS 1 TIME EACH

NOTE ( 1 ) : Ta AT -30° C: WILL BE < 48hrs

80° C: WILL BE < 168hrs

NOTE ( 2 ) : Ta ≤ 60° C : 90%RH MAX. (96HRS MAX.)

Ta > 60° C : ABSOLUTE HUMIDITY MUST BE

LOWER THAN THE HUMIDITY OF 90%RH AT 60° C. (96HRS MAX.)

### 4 . ELECTRICAL CHARACTERISTICS Ta=25° C

ITEM	SYMBOL	CONDITION	MIN.	TYP.	MAX.	UNIT
POWER SUPPLY	V <sub>DD</sub>	—	3.0	3.3	5.25	V
SUPPLY CURRENT FOR LOGIC NOTE	I <sub>DD</sub>	V <sub>DD</sub> =3.3V, CPU=3MHz	—	(8)	(14)	mA
SLEEP (MODE) CURRENT NOTE( 1 )	I <sub>SB</sub>	V <sub>DD</sub> =3.3V, -40° C ≤ TA ≤ 85° C	—	(3.0)	(25)	μA

NOTE ( 1 ) : WITH POR, LVD, SLEEP TIMER, WDT, AND INTERNAL SLOW OSCILLATOR ACTIVE.

### 5 . TIMING CHARACTERISTICS

#### 5 . 1 AC CHARACTERISTICS OF THE I2C SDA AND SCL PINS

SYMBOL	DESCRIPTION	STANDARD MODE		FAST MODE		UNITS
		MIN.	MAX.	MIN.	MAX.	
FSCLI2C	SCL CLOCK FREQUENCY	0	100	0	400	KHz
THDSTAI2C	HOLD TIME (REPEATED) START CONDITION. AFTER THIS PERIOD, THE FIRST CLOCK PULSE IS GENERATED.	4.0	—	0.6	—	μs
TLOWI2C	LOW PERIOD OF THE SCL CLOCK	4.7	—	1.3	—	μs
THIGHI2C	HIGH PERIOD OF THE SCL CLOCK	4.0	—	0.6	—	μs
TSUSTA2C	SET-UP TIME FOR A REPEATED START CONDITION	4.7	—	0.6	—	μs
THDDATI2C	DATA HOLD TIME	0	—	0	—	μs
TSUDATI2C	DATA SET-UP TIME	250	—	100	—	μs
TSUSTOI2C	SETUP TIME FOR STOP CONDITION	4.0	—	0.6	—	μs
TBUFI2C	BUS FREE TIME BETWEEN A STOP AND START CONDITION	4.7	—	1.3	—	μs
TSPI2C	PULSE WIDTH OF SPIKES ARE SUPPRESSED BY THE INPUT FILTER	—	—	0	50	μs





PIN NO.	SYMBOL	FUNCTION
1	VDD	SUPPLY VOLTAGE, BYPASS TO GROUND WITH 0.1μF CAPAITOR.
2	I2C_SDA	DATA ACCESS SIGNAL; HOST WRITING DATA TO OR READING DATA FROM DRIVER IC
3	I2C_SCL	CLOCK SIGNAL;INPUT FROM HOST
4	VSS	GROUND
5	RESET	ACTIVE HIGHT EXTERNAL RESET WITH INTERNAL PULL DOWN
6	INT	INTERRUPT SIGNAL; ACTIVE LOW WHEN FINGER TOUCHING ON THE SCREEN

## 11 . PROCOTOL

### 11.1 CONFIGURATION

INTERFACE	I2C SLAVE
SLAVE ADDRESS	0X38H
TRANSLATE RATE	UP TO 100KHZ
REPORT RATE	35~85 POINTS/SEC
GESUTURE	ZOOM IN/OUT, SLIDE X, SLIDE Y

### 11.2 DATA FORMAT

S	ADDRESS	R		DATA1	A	DATA2	A	DATA3	A	DATA4	A	
								DATA5	A	DATA6	N	P

FROM MASTER TO SLAVE	S	= START CONDITION
	P	= STOP CONDITION
FROM SLAVE TO MASTER	A	= ACKNOWLEDGE
	N	= NOT ACKNOWLEDGE
	R	= READ
	ADDRESS	= 7-BIT (03H)
	DATA	= 8-BIT

### 11.3 REPORT DATA RANGE

X POSITION = ( DATA1<<8 )|( DATA2 );

Y POSITION = ( DATA3<<8 )|( DATA4 );

X(min)=0 ,X(max)=2047

Y(min)=0 ,Y(max)=2047

GESTURE	DATA5	DATA6
NONE	0x00	0x00
ROTATION -- LEFT	0X21	0x00~0xFF
ROTATION -- RIGHT	0X22	0x00~0xFF
ZOOM IN	0x31	0x00~0xFF
ZOOM OUT	0x32	0x00~0xFF
SLIDE X --RIGHT	0x41	0x00~0xFF
SLIDE X --LEFT	0x42	0x00~0xFF
SLIDE Y --UP	0x43	0x00~0xFF
SLIDE Y --DOWN	0x44	0x00~0xFF

## 11.4 EXAMPLE

ASSUME THE FINGER TOUCH THE PANEL  
AND GET DATA1= 0x0, DATA2=0x3C, DATA3=0x01,  
DATA4=0x18, DATA5=0x00, DATA6=0x00

THEN

X = (0x0<<8) | 0x3C = 0x3C → 60

Y = (0x1<<8) | 0x18 = 0x118 → 280

GESTURE = NONE

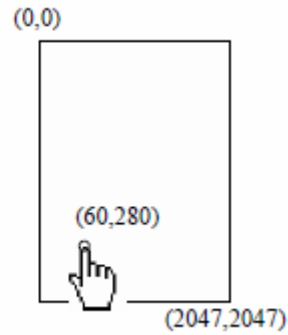

## 12. INSPECTION CONDITIONS

### 12.1 ENVIRONMENTAL CONDITIONS

- (1) OBSERVATION DISTANCE:  $30 \pm 5$ cm
- (2) VIEW ANGLE:  $\pm 45^\circ$
- (3) BACKLIGHTGROUND: BLACK
- (4)

AMBIENT TEMPERATURE	20°C ~ 30°C
AMBIENT HUMIDITY	55±10%RH
AMBIENT ILLUMINATION (FLUORESCENT LIGHT)	>1500LUX

VIEWING ANGLE SHOULD BE SMALLER THAN  $45^\circ$

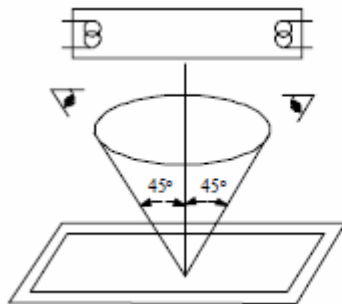

THE LINE OF SIGHT FOR INSPECTION SHALL BE INSIDE THE HALF SECTION OF A CONE WHICH CONSISTED OF LINE SEGMENT  $45^\circ$  TO THE AXIS WITH VERTEX AT THE CENTER OF LCD, THE CONE AXIS PER- PENTICULAR TO THE LCD AND PASSING THROUGH THE FLUORESCENT LAMP.

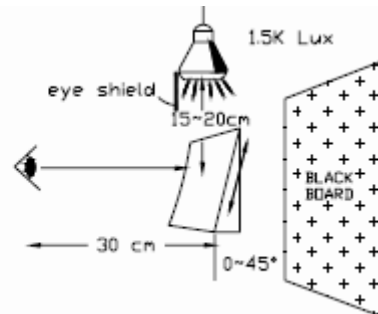

A AREA : VIEWING AREA  
B AREA : OUT OF VIEWING AREA  
(OUTSIDE VIEWING AREA)

### 12.2 INSPECTION PLAN

FOLLOW MIL-STD-105E, NORMAL, LEVEL II, AQL=1.0

13. INSPECTION STANDARDS

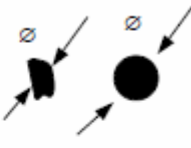
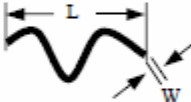
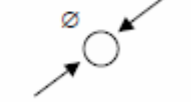
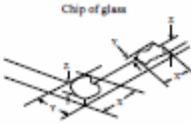
INSPECTION ITEMS	CRITERIA	REMARK								
BLACK/WHITE SPOT	THE FOLLOWING BLACK/WHITE SPOT ARE WITHIN THE VIEWING AREA. AVERAGE DIAMETER : D mm									
	<table border="1"> <thead> <tr> <th>SIZE D</th> <th>PERMISSIBLE NO.</th> </tr> </thead> <tbody> <tr> <td><math>D \leq 0.1\text{mm}</math></td> <td>IGNORE</td> </tr> <tr> <td><math>0.1\text{mm} &lt; D \leq 0.5\text{mm}</math></td> <td>5</td> </tr> <tr> <td><math>D &gt; 0.5\text{mm}</math></td> <td>0</td> </tr> </tbody> </table>		SIZE D	PERMISSIBLE NO.	$D \leq 0.1\text{mm}$	IGNORE	$0.1\text{mm} < D \leq 0.5\text{mm}$	5	$D > 0.5\text{mm}$	0
SIZE D	PERMISSIBLE NO.									
$D \leq 0.1\text{mm}$	IGNORE									
$0.1\text{mm} < D \leq 0.5\text{mm}$	5									
$D > 0.5\text{mm}$	0									
	NOTE (1) : THE DISTANCE BETWEEN DOT EFFECTS SHOULD BE MORE THAN 10mm APART.									
SCRATCH	THE FOLLOWING BLACK LINE, WHITE LINE IS WITHIN THE VIEWING AREA. WIDTH : W mm , LENGH : L mm									
	<table border="1"> <thead> <tr> <th>SIZE W &amp; L</th> <th>PERMISSIBLE NO.</th> </tr> </thead> <tbody> <tr> <td><math>W \leq 0.02\text{mm}</math></td> <td>IGNORE</td> </tr> <tr> <td><math>0.02\text{mm} &lt; W \leq 0.03\text{mm}, L \leq 5\text{mm}</math></td> <td>3</td> </tr> <tr> <td><math>0.03\text{mm} &lt; W \leq 0.05\text{mm}, L \leq 5\text{mm}</math></td> <td>2</td> </tr> <tr> <td><math>W &gt; 0.05\text{mm}</math></td> <td>0</td> </tr> </tbody> </table>		SIZE W & L	PERMISSIBLE NO.	$W \leq 0.02\text{mm}$	IGNORE	$0.02\text{mm} < W \leq 0.03\text{mm}, L \leq 5\text{mm}$	3	$0.03\text{mm} < W \leq 0.05\text{mm}, L \leq 5\text{mm}$	2
SIZE W & L	PERMISSIBLE NO.									
$W \leq 0.02\text{mm}$	IGNORE									
$0.02\text{mm} < W \leq 0.03\text{mm}, L \leq 5\text{mm}$	3									
$0.03\text{mm} < W \leq 0.05\text{mm}, L \leq 5\text{mm}$	2									
$W > 0.05\text{mm}$	0									
LINEAR TYPE / FOREIGN FIBER										
	<table border="1"> <thead> <tr> <th>SIZE W &amp; L</th> <th>PERMISSIBLE NO.</th> </tr> </thead> <tbody> <tr> <td><math>W \leq 0.02\text{mm}</math></td> <td>IGNORE</td> </tr> <tr> <td><math>0.02\text{mm} &lt; W \leq 0.03\text{mm}, L \leq 5\text{mm}</math></td> <td>2</td> </tr> <tr> <td><math>0.03\text{mm} &lt; W \leq 0.05\text{mm}, L \leq 5\text{mm}</math></td> <td>1</td> </tr> <tr> <td><math>W &gt; 0.05\text{mm}</math></td> <td>0</td> </tr> </tbody> </table>		SIZE W & L	PERMISSIBLE NO.	$W \leq 0.02\text{mm}$	IGNORE	$0.02\text{mm} < W \leq 0.03\text{mm}, L \leq 5\text{mm}$	2	$0.03\text{mm} < W \leq 0.05\text{mm}, L \leq 5\text{mm}$	1
SIZE W & L	PERMISSIBLE NO.									
$W \leq 0.02\text{mm}$	IGNORE									
$0.02\text{mm} < W \leq 0.03\text{mm}, L \leq 5\text{mm}$	2									
$0.03\text{mm} < W \leq 0.05\text{mm}, L \leq 5\text{mm}$	1									
$W > 0.05\text{mm}$	0									
BUBBLE / DENT	BUBBLES IS IN THE VIEWING AREA. AVERAGE DIAMETER : D mm									
	<table border="1"> <thead> <tr> <th>SIZE D</th> <th>PERMISSIBLE NO.</th> </tr> </thead> <tbody> <tr> <td><math>W \leq 0.2\text{mm}</math></td> <td>IGNORE</td> </tr> <tr> <td><math>0.2\text{mm} &lt; W \leq 0.3\text{mm}</math></td> <td>3</td> </tr> <tr> <td><math>0.3\text{mm} &lt; W \leq 0.5\text{mm}</math></td> <td>1</td> </tr> <tr> <td><math>W &gt; 0.5\text{mm}</math></td> <td>0</td> </tr> </tbody> </table>		SIZE D	PERMISSIBLE NO.	$W \leq 0.2\text{mm}$	IGNORE	$0.2\text{mm} < W \leq 0.3\text{mm}$	3	$0.3\text{mm} < W \leq 0.5\text{mm}$	1
SIZE D	PERMISSIBLE NO.									
$W \leq 0.2\text{mm}$	IGNORE									
$0.2\text{mm} < W \leq 0.3\text{mm}$	3									
$0.3\text{mm} < W \leq 0.5\text{mm}$	1									
$W > 0.5\text{mm}$	0									
CHIP ON GLASS										
	<table border="1"> <tbody> <tr> <td>CORNER</td> <td><math>X \leq 3\text{mm} \cdot Y \leq 3\text{mm} \cdot Z \leq t</math> (t : thickness)</td> </tr> <tr> <td>EDGE</td> <td><math>X \leq 6</math> <math>Y \leq 1\text{mm} \cdot Z \leq t</math></td> </tr> </tbody> </table>		CORNER	$X \leq 3\text{mm} \cdot Y \leq 3\text{mm} \cdot Z \leq t$ (t : thickness)	EDGE	$X \leq 6$ $Y \leq 1\text{mm} \cdot Z \leq t$				
CORNER	$X \leq 3\text{mm} \cdot Y \leq 3\text{mm} \cdot Z \leq t$ (t : thickness)									
EDGE	$X \leq 6$ $Y \leq 1\text{mm} \cdot Z \leq t$									
CRACK	NOT ACCEPTABLE									

NOTE: 1. IF WE CANNOT SEE ANY SPOT OR LINE IN THE APPROPRIATE OPERATING CONDITION OF PANEL, IT IS ACCEPTABLE.

2. THE FOREIGN MATERIALS THAT CAN BE BLOWN OUT BY AIR AND WASHED OUT BY WET CLEANING ARE NOT REGARDED AS A DEFECT.

14 GENERAL RELIABILITY ASSURANCES

NO	ITEM	CONDITIONS	TIME PERIOD	REMARK
1	HIGH TEMPERATURE STORAGE	80 ± 2 °C 15% RH	240HRS	2HR LEAVING ALONE AT NORMAL TEMP
2	LOW TEMPERATURE STORAGE	-30 ± 2 °C <15% RH	240HRS	4HR LEAVING ALONE AT NORMAL TEMP
3	HIGH TEMPERATURE OPERATION	70 ± 2 °C	240HRS	AS SAME AS (2)
4	LOW TEMPERATURE OPERATION	-20 ± 2 °C	240HRS	AS SAME AS (2)
5	HIGH TEMPERATURE HUMIDITY STORAGE	60 ± 2 °C 90 % RH	240HRS	AS SAME AS (2)
6	THERMAL SHOCK	-30°C , 70°C 0.5H 0.5H	TRANSIT/3MIN 50 CYCLE	
7	FPC BENDING TEST	0° TO 135°	RIGHT 90°INVERSE 45° POISE 500G, 10 CYCLE	WITHOUT FUNCTION ISSUE
8	ESD	AIR±12KV	—	ONLY TP LCM
		CONTACT±8KV		

NOTE ( 1 ) : AFTER COMPLETING THE RELIABILITY TEST, CHECK:

1. IF THE TOUCH PANEL WORKS NORMALLY IN NORMAL TEMPERATURE ENVIRONMENT.
2. IF THERE IS ANY VARIATION FOR THE APPEARANCE.

NOTE ( 2 ) :

- 1.DO THE EXAMINATION AND THE MEASUREMENT UNDER THE FOLLOWING CONDITIONS, EXCEPT SPECIFIED IN EACH ITEM. TEMPERATURE: 25 ± 5° C HUMIDITY: 55 ± 10%RH ATMOSPHERIC PRESSURE: 96 ± 10KPA
2. ALL MEASUREMENTS SHALL NOT BE STARTED UNTIL THE SPECIMENS ATTAIN TO TEMPERATURE STABILITY

15. ATTENTION  
CLEANING

- (1) USE NEUTRAL DETERGENT OR ACETONE ON A CLEAN SOFT CLOTH TO CLEAN THE PANEL SURFACE.
- (2) PREVENT USING ANY KIND OF CHEMICAL SOLVENT, ACIDIC OR ALKALI SOLUTION.